

**General Specifications**

Input Voltage	220-240VAC, 50/60Hz
Input Current	0.27A Max.
Input Power	58W
Power Factor	>0.9
THD	<20%
Standby Power	<0.5W
Output Type	SELV
Output Current	250-1400mA
Output Voltage Range	11-50VDC
Output Power	45W (1W to 6W @ Emergency)
Output runtime	Minimum 90min at 6W, Minimum 180 Minutes at 3W (Factory set for 3W / 180min)
Dimming Type	0-10V or Pulse DIM
Dimming Percentage	0%, 1%-100%
Number of Output Channels	1 Channel
RFI/EMI	EN55015
Ambient Operating Temperature Range	0°C To 40°C (32°F To 104°F)
Sound Rating	A
Input Surge Protection	Line-Neutral 2kV, Line & Neutral-Ground 2kV
Protections	Output Open Circuit Protection Overload Protection Short-Circuit Protection Battery Deep Discharge Protection Over Temperature Protection
Service Life	50,000 hours
Self-Diagnostic	Factory Enabled
Safety Standards	IEC/EN 61347-1, IEC/EN 61347-2-7, IEC/EN 61347-2-13, IEC/EN 60598-1 IEC/EN 60598-2-22, IEC 62384, EN 62493, IEC / EN 62034 EN 61547, EN 55015, EN 61000-3-2, EN 61000-3-3

**Mechanical Data**

Tolerance=±0.02"[0.5mm]

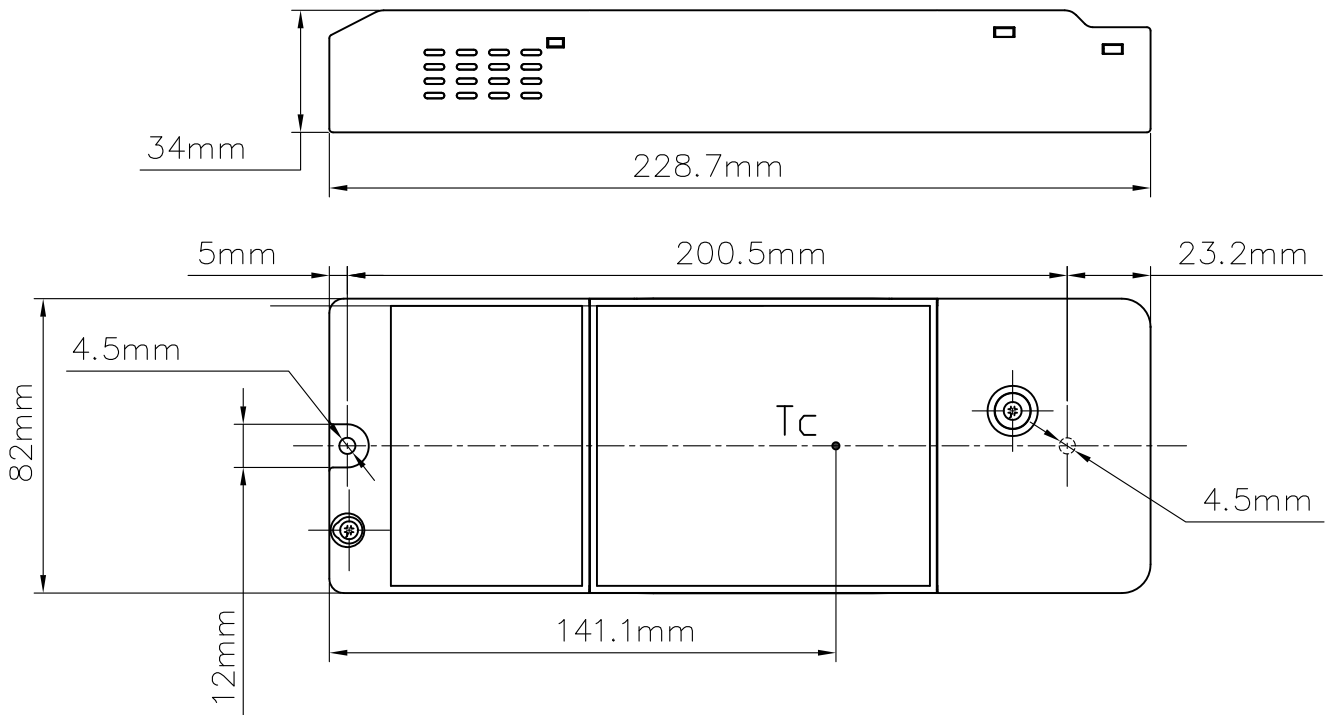

Fulham extends a limited warranty to the original purchaser or first user for a period of 5 years from the date of manufacture when properly installed and operated under normal conditions of use. For complete terms and conditions, please refer to the Warranty Center at [www.fulham.com](http://www.fulham.com). Specifications subject to change without notice.

## Important Safety Instructions

When using electrical equipment and this lighting device basic safety precaution should be followed at all times including but not limited to the following:

**PLEASE READ CAREFULLY AND FOLLOW ALL INSTRUCTIONS FOR YOUR OWN SAFETY**

**Important: An un-switched AC power source of 220VAC to 240VAC is required.**

**Important: Double insulation used between the supply and battery circuit.**

**Important: Intermittent re-charging circuit.**

**Important: The recharging device remains safe after abnormal operating condition.**

**Caution:** Do not let power supply cords touch hot surfaces.

**Caution:** Do not mount near gas or electric heaters.

**Caution:** Do not use outdoors.

**Caution:** Battery is rechargeable LiFePO4 type and must be recycled or disposed of properly.

Do not use this emergency driver with accessory equipment other than recommended by manufacturer; failure to follow this may cause an unsafe condition. Servicing should only be performed by qualified service personnel.

Do not use this emergency driver for other than intended use.

Equipment should be mounted in locations and at heights where it will not readily be subjected to tampering by unauthorized personnel.

**Important:** Indicator (LED light) illuminated indicates battery in charge mode when AC power is applied.

It is recommended and required by applicable code to test emergency function to ensure proper operation of the system; push the test switch for thirty (30) seconds every 30 days to ensure the emergency driver is functioning as by illuminating the LED light source. Conduct a ninety minute (90) discharge test one time (1) per year; LED light source should be illuminated for a minimum of ninety minutes (90).

**ASSEMBLY and FIELD INSTALLATION WIRING: WARNING:** AC power must be off before proceeding with assembly or installation of emergency driver.

**TESTING SYSTEM:** The emergency battery requires a charge minimum of one (1) hour before testing the circuit. A full charge requires twelve (12) hours.

Fulham Head Quarters:  
Fulham Co., Inc  
12705 South Van Ness Ave.  
Hawthorne, CA 90250  
Local: (323) 779-2980, Fax: (323) 754-9060

Manufacturer:  
North China  
Fulham Electronic Co. Ltd.  
No. 9 Xingchang Road, Nanshao Zhen Changping Science Park, Beijing, P.R. China

Fulham extends a limited warranty to the original purchaser or first user for a period of 5 years from the date of manufacture when properly installed and operated under normal conditions of use. For complete terms and conditions, please refer to the Warranty Center at [www.fulham.com](http://www.fulham.com). Specifications subject to change without notice.

STEP 1: Remove the Screw

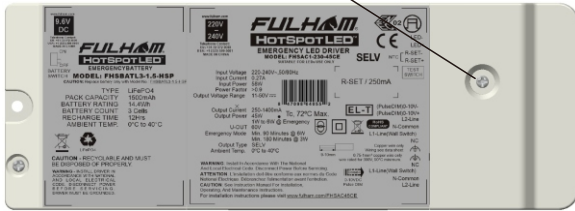

STEP 2: Remove the cover

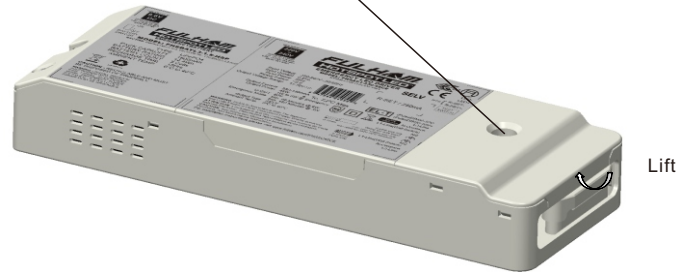

STEP 3: Remove the Screws and strain covers



STEP 4: Mounting the LEDdriver

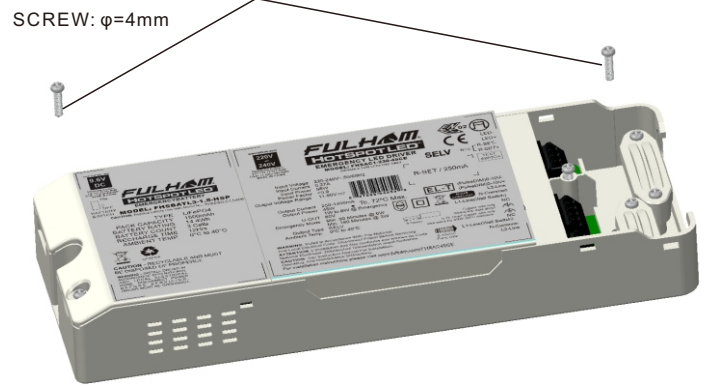

**A** Mounting the LED driver

STEP 1: Wiring according to actual needs.  
Press the cord wires into the strain relief slots.

STEP 2: Put on the strain covers.  
SCREW:  $\varphi=3\text{mm}$

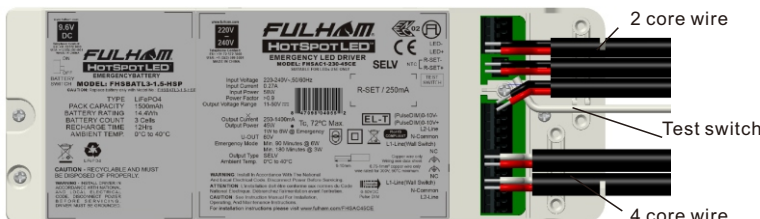

**B** Making the wire connections

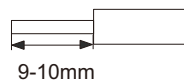

NOTE: 1. Copper wire only  
0.75-1mm<sup>2</sup> copper wire only and wire rated for 300V, 90°C minimum.

Fulham extends a limited warranty to the original purchaser or first user for a period of 5 years from the date of manufacture when properly installed and operated under normal conditions of use. For complete terms and conditions, please refer to the Warranty Center at [www.fulham.com](http://www.fulham.com). Specifications subject to change without notice.

STEP 1: Close the cover

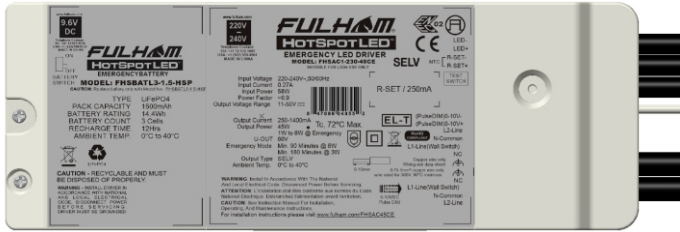

STEP 2: Mounting the screw

SCREW:  $\phi=3\text{mm}$

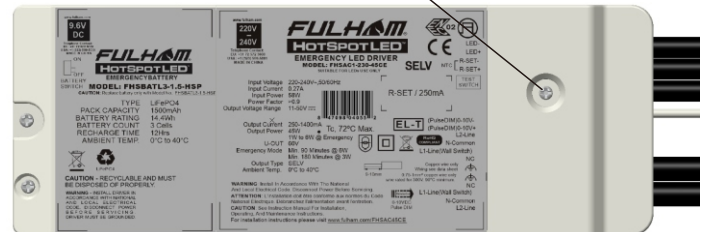

**C** Close the cover

STEP 1: Move battery switch to the "OFF" position.

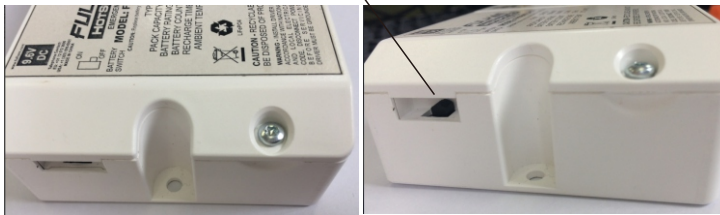

STEP 2: Remove the screw

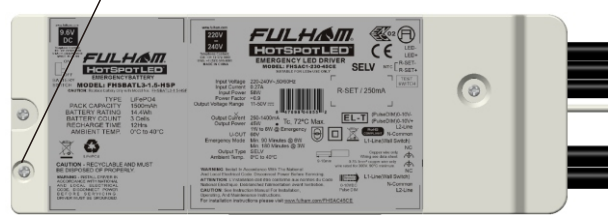

STEP 3: Remove the cover

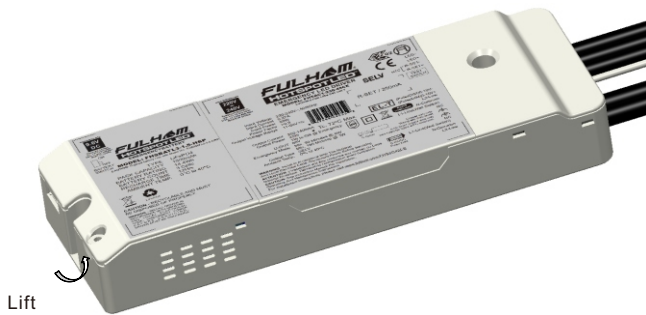

**D** Replace battery

Fulham extends a limited warranty to the original purchaser or first user for a period of 5 years from the date of manufacture when properly installed and operated under normal conditions of use. For complete terms and conditions, please refer to the Warranty Center at [www.fulham.com](http://www.fulham.com). Specifications subject to change without notice.

**STEP 4: Remove the battery**



Disconnect connector

Take out the battery

**STEP 5: Install new battery**

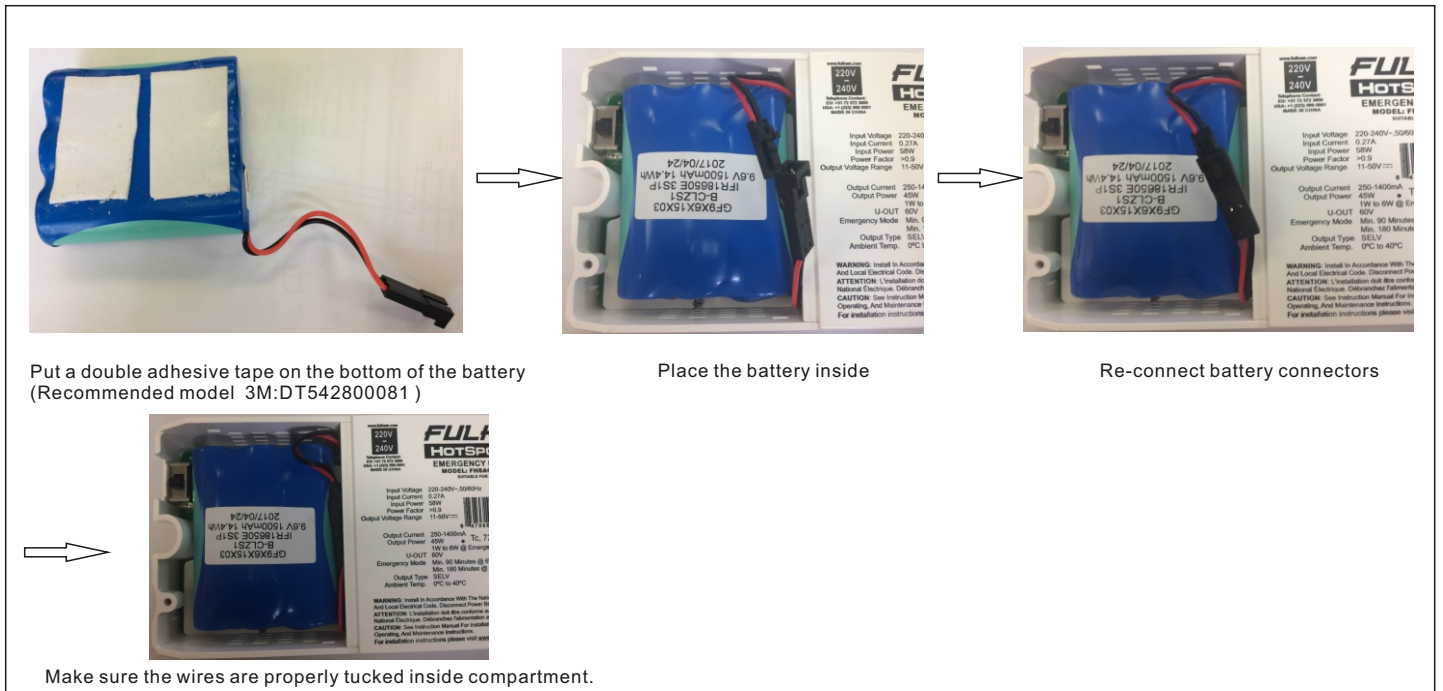

Put a double adhesive tape on the bottom of the battery (Recommended model 3M:DT542800081)

Place the battery inside

Re-connect battery connectors

Make sure the wires are properly tucked inside compartment.

**STEP 6: Close the cover**

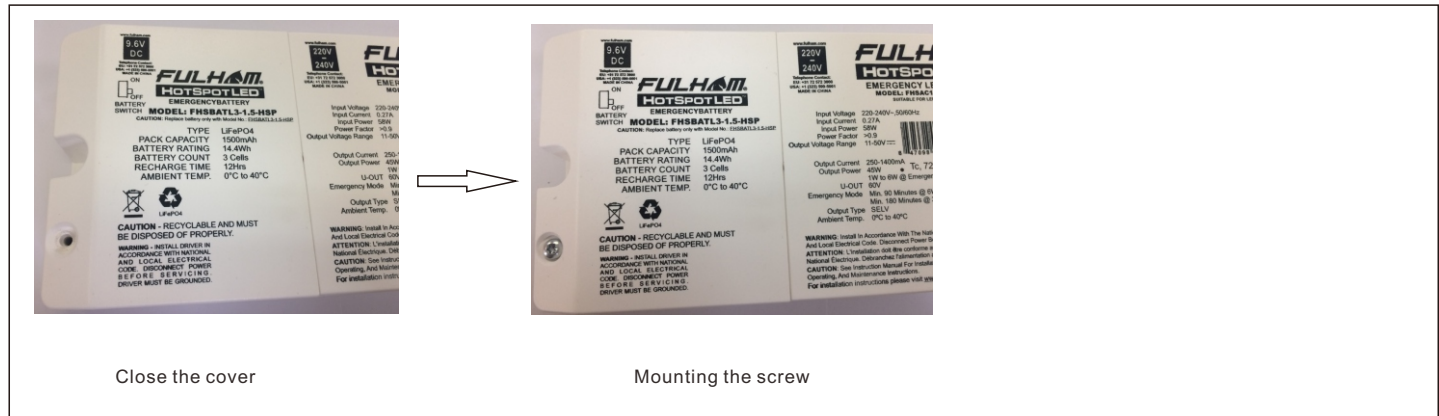

Close the cover

Mounting the screw

**D Replace battery**

Fulham extends a limited warranty to the original purchaser or first user for a period of **5 years** from the date of manufacture when properly installed and operated under normal conditions of use. For complete terms and conditions, please refer to the Warranty Center at [www.fulham.com](http://www.fulham.com). Specifications subject to change without notice.

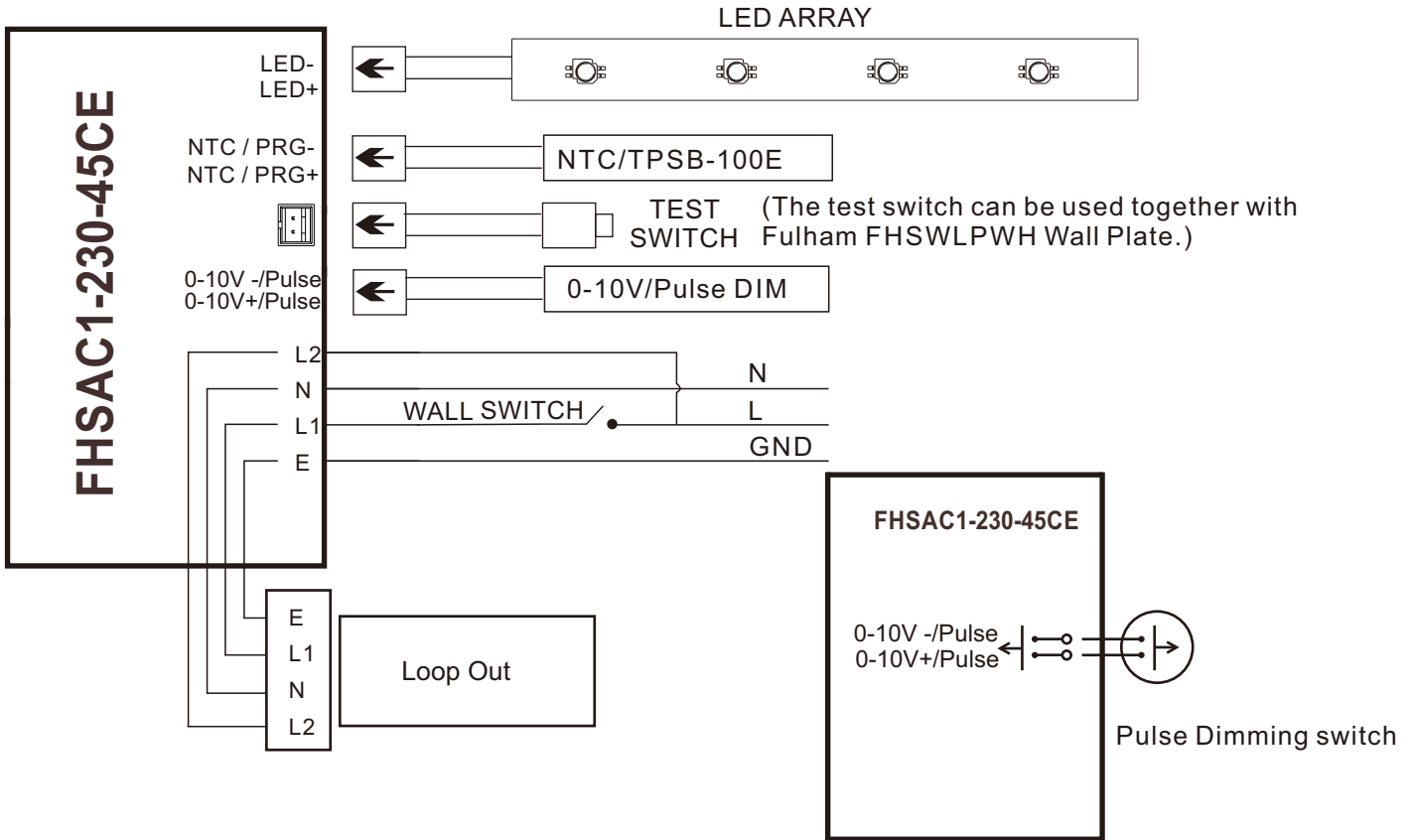

**Description:** The Fulham FHSWLPWH Wall Plate can be used when remote mounting the Lighted Push Button Test Switch (LPBTS) next to the fixture, on the wall or in any location within the maximum remote mounting distance (15 meters) of the Lighted Push Button Test Switch (LPBTS).



**Wall plate and screw color:  
white with black lettering**

Fulham extends a limited warranty to the original purchaser or first user for a period of 5 years from the date of manufacture when properly installed and operated under normal conditions of use. For complete terms and conditions, please refer to the Warranty Center at [www.fulham.com](http://www.fulham.com). Specifications subject to change without notice.

Self-Diagnostic tests to insure the unit is properly functional . It will test the following parameters:

- \*Battery-Checks to insure battery is properly connected and has sufficient capacity for 180 minutes when set to 1-3W or 90 minutes when set to 4W-6W
- \*LED load-Insures LED load is connected properly and functional.
- \*Charging circuit-Insures unit charging circuit is functioning properly.

Any errors will be shown via the indicator light as per the table below:

LED indicators on TEST SW	System Status
Permanent green	System OK
Slow flashing green (1 sec on – 1 sec off)	Self-Diagnostic process underway
Flashing Red (4 sec on – 1 sec off)	Battery not connected, check BAT pack
Solid Red	Load failure, check EM LED load.
Slow flashing red (1 sec on – 1 sec off)	Battery failure, replace BAT pack.
Fast flashing red (0,5 sec on – 0,5 sec off)	Charge circuit error, replace EM Driver.
Both Green & Red off	EM Mode

#### TEST SWITCH OPERATIONS:

##### Emergency Test Mode

1. Press and Hold Test Button to test Emergency Mode.  
This can be done in all normal AC powered situations including dimmed to off and switched off.

##### Manual Self-Diagnostic

1. Quickly Press Test Button 3 times within 3 seconds to manually activate Self-Diagnostic cycle.  
This will test the unit for 180 minutes when EM power set for 1W to 3W or for 90 minutes when EM power is set for 4W or 6W.
2. To Exit the Self-Diagnostic cycle, Press and Hold Test Button for 5 seconds

##### Enable / Disable Auto Self-Diagnostic

1. Press and Hold Test Button for 3 seconds
2. Release and Quickly Press Test Button 2 times
3. Press and Hold Test Button again for 3 seconds
4. Green Indicator on Test Button will flash for 5 seconds indicating the Enabled or Disabled Status :  
Short off / Long on = Enabled  
Long off / short on = Disabled

**PROGRAMMING:**

The following features can be programmed on this driver using the Fulham SmartSet TPSB-100E Handset:

- \* Output Current - 250mA to 1400mA
- \* Output EM power - 1W to 6W
- \* Enable / Disable Auto Self-Diagnostic Function
- \* Dimming :0-10V,0-10V Log,0-10V Custom or Pulse Dimming.

In order to configure the last 3 items, the TPSB-100E must be in FULL FEATURE mode.

The Output Current, EM Power, Dimming Profile and Auto Self-Diagnostic Status can also be configured by using the Fulham SmartSet PC software.

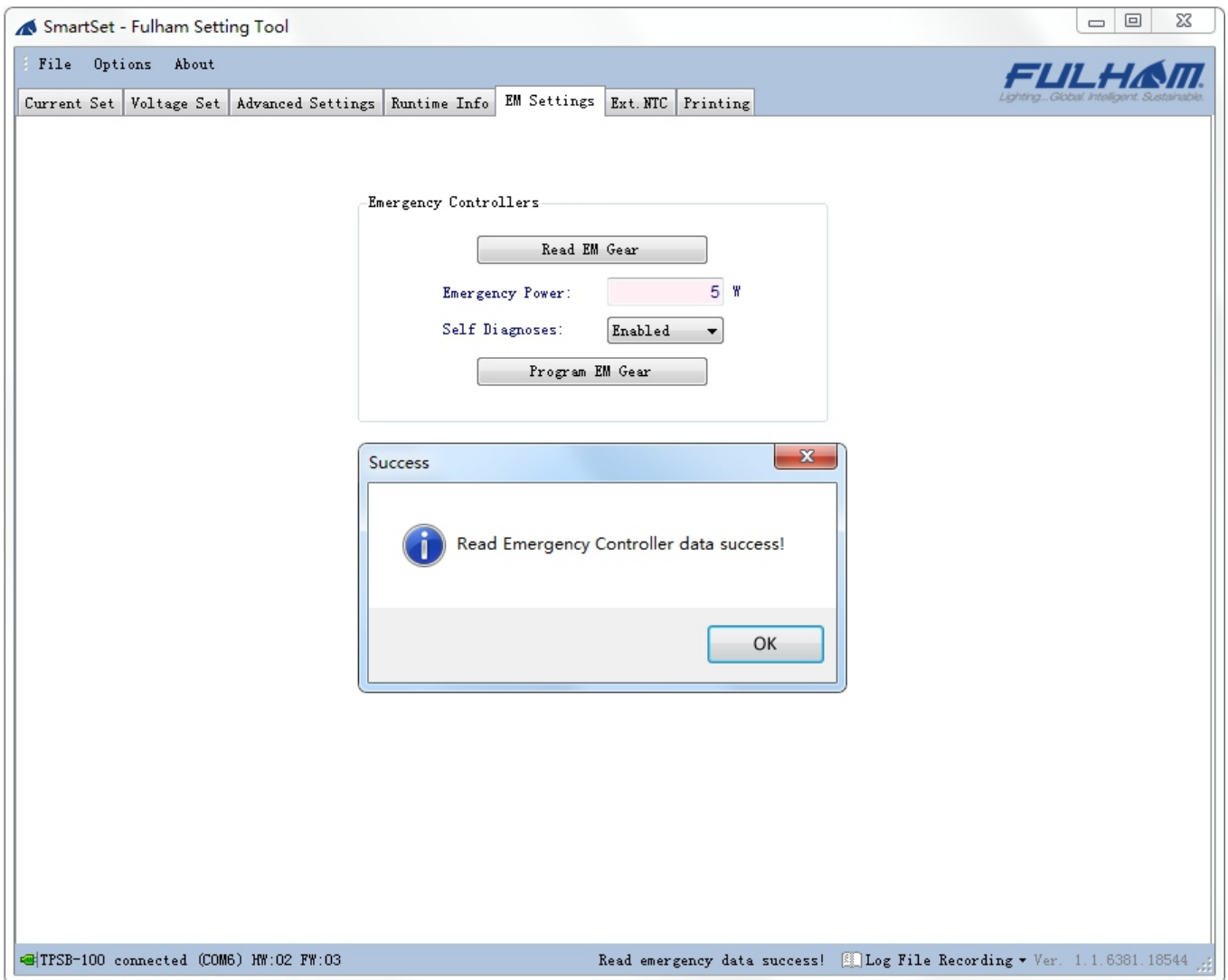

\*For more detailed programming instructions please see our Programming Instructions and Design Guide found on our website.